

Instruction Manual

Thank you for purchasing this new product. Please read through this instruction manual thoroughly to operate this product correctly and keep it near the product so that you may refer to it whenever necessary. If you transfer the product to another customer, be sure to attach this instruction manual and the warranty information to the product.

Product Name	Sensor Unit (for the DIN 3 Meter)
Product Code	409-A005
Application	Various Sensor Inputs Communication Unit with DIN 3 Meter
Applicable Vehicle	DC10V~16V Body Earth Vehicle
Operating Temperature	±0~+60°C

Before Installation and Use This instruction manual is intended to be used for the A' PEXi DIN 3 Meter. Please also refer to the instruction manual for the DIN 3 Meter Main Unit that supports the installation of this product.

Version Information

No.	Date of Issue	Instruction Manual Ver.	#	Notes
1	June 1, '12	7207-0370-00	1	
2	July 6, '12	7207-0370-01	2	
3	Feb 19, '15	7207-0370-02	3	

Contact
Apex Co., Ltd.
 9-1 Matsugi Hachioji-City, Tokyo, 192-0362 Japan.
 Tel: +81-42-678-7130 Fax: +81-42-678-7131
Apex Integration Inc.
 1449 West Orange Grove Avenue, Suite#A, Orange, CA 92868 USA
 Tel: +1-714-685-5700 Fax: +1-714-685-5701

©Apex Co., Ltd. Printed in Japan

- It is strictly prohibited to reproduce or copy any portion of this manual. This manual may not be used for any other purposes than personal use without expressed written consent of A' PEXi.
- We are not responsible for any losses resulting from data memory loss caused by faulty installation, accidents, or any other factors.
- A' PEXi reserves the right to improve and change optional parts, part numbers, prices, and configurations without prior notice.

2 Safety Precautions

Please read "Safety Precautions" carefully to operate the product with safety. Keep the instruction manual in hand and refer to it whenever needed. The instruction manual describes the items that you must observe prior to installation and use of this product to avoid possible problems and damage which would be caused by improper installation and use. The meanings of pictorial indications by caution marks (signal words) are shown below. Please understand their contents correctly before starting to read the text of this instruction manual.

GLOSSARY

Display	Meanings	Display	Meanings
	Potential hazard that can result in death or serious injury of the operator or a third person if the product is wrongly operated in disregard of this indication.		Potential hazard that can result in slight injury or medium damage to the operator, third person, or vehicle if the instruction manual is not followed correctly.

WARNING

- Discontinue use of this product immediately if any unusual odor or smoke comes from the unit. Failure to do so may result in electrical shorts and potential engine fire. Please consult with your distributor or nearest local installation shop.
- Always remove the negative terminal (-) of the battery before attempting installation. Failure to do so may result in electrical fires and engine fires resulting in damaged products. After installation with the negative battery terminals disconnected, recorded ECU memory, idling learning system, anti-theft systems, vehicle radio security systems, etc. may be reset. In this case please refer to your vehicle's factory owner's manual for further information.
- Always wire this unit up according to the instruction manual. Failure to do so may result in electrical fire, improper unit/ vehicle operation.
- Mount this product securely. Do not install nor mount the product in an unstable location that may interfere with driving which can result in an accident.
- Never operate this unit while driving. This may interfere with driving operations which can result in unexpected accidents and/or problems.
- Do not install and use this product and its accessories for any other purpose than the one specified by A' PEXi in this manual. In this case, we shall disclaim all responsibility for any damage or loss to the customer or third persons from improper usage of this product.

CAUTION

- This product should only be installed by a trained professional installer. Installation requires past experience, technical knowledge and skill to prevent damage to the unit and vehicle.
- Never disassemble or tamper with this unit. Failure to do so may lead to electrical short circuits and electrical fires resulting in product and engine damage.
- Do not drop this product or expose it to excessive shock. Failure to do so may result in product malfunction and engine damage/vehicle.
- Do not operate this unit in excessively hot or high-temperature vehicle interiors that are not air-conditioned during hot weather seasons. Failure to do so may result in unit malfunction, thereby resulting in damage to the product and the vehicle.
- Keep this unit away from direct water and sunlight. Failure to do so may result in electrical shorts causing product and vehicle damage.
- Be sure to perform installation of unit parts when engine bay area is at cool temperatures. Failure to do so may result in burning oneself.

1 Parts List

This manual contains the parts list of each individual product for the DIN 3 Meter. Be sure to check the contents of the product BEFORE installation. If any parts are missing or damaged, please repack the unit and all of its contents and return to your dealer of purchase with proof of purchase.

- Sensor Unit Product Code 409-A005
 - Sensor Unit ...1
 - COM Harness ...1
 - Power Supply Harness ...1
 - Wire Terminals ...2
 - Zip Tie ...5
 - Mounting Screw Set ...1
 - Instruction Manual (English) ...1

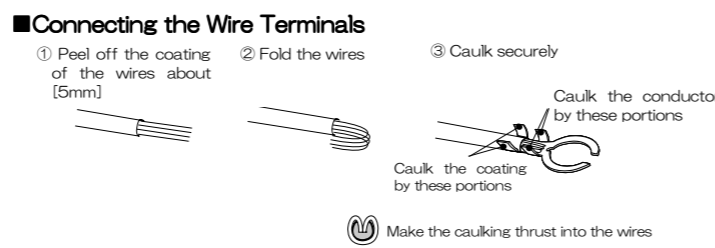

3 Part Descriptions

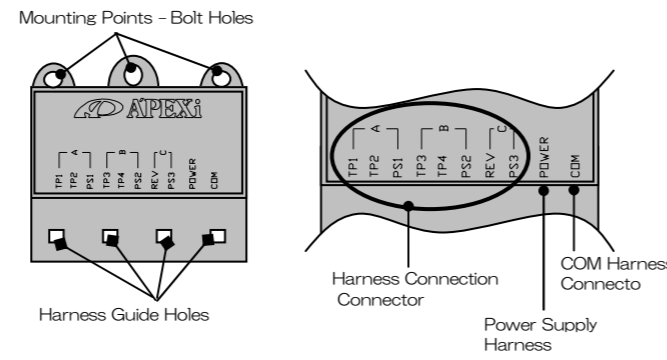

Harness Connection Connector Guide

A	TP1 . . Temperature Sensor (Water / Oil)	B	TP3 . . -
	TP2 . . Temperature Sensor (Water / Oil)		TP4 . . -
	PS1 . . Pressure Sensor (Oil)		PS2 . . -
C	REV . . -		
	PS3 . . -		

In the case of using 409-A003 Meter, then, the [B] and [C] couplers will not be used. Even if connected the [B] and [C] couplers, the contents will not be displayed.

4 Installation Procedures

Installation Diagram

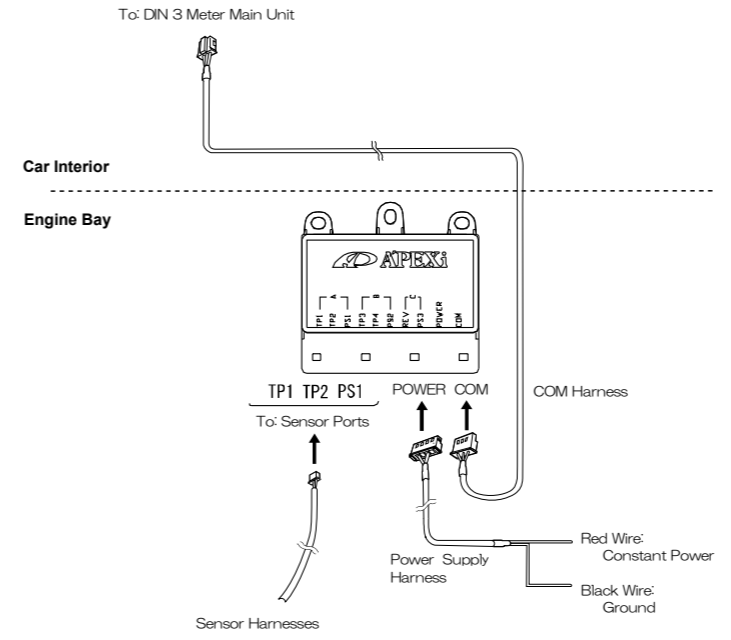

Power Supply Harness Connection

- The Sensor Unit requires the connection of Constant Power and Ground.
- Mount the Sensor Unit in a location that does not interfere with the wiring harness connections for both the sensor and power supply.
- Connecting the wires can be done by using the included wire terminals and splices or by using professional soldering equipment. Be sure that each wire has a secure connection.

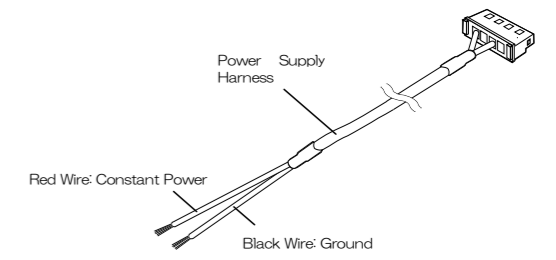

※ It is also possible to connect the Power Supply Wiring Harness directly to the Battery. The Sensor Unit Power ON / OFF switch is controlled through the COM Harness connected to the DIN 3 Meter.
 [Memo.] Standby Power Off Requirement . . . 5mA or less

- CAUTION**
- Always remove paint and oil from any Grounding location to prevent faulty connections.
 - Do not use electro-taps during installation. Electro-taps may come loose after time causing faulty connections. This may lead to product failure and vehicle damage.
 - Be sure to route the wiring harness away from moving parts and HOT areas. If in a HOT area, be sure to wrap the harness with some type of insulation.

Sensor Unit Installation

- Be sure to mount in a location where wiring harnesses can reach sensor unit, and use the included mounting hardware and zip ties to securely fasten to mounting location.
- Be sure to mount the sensor unit as shown in the drawing below with the sensor harness connections faced downward.

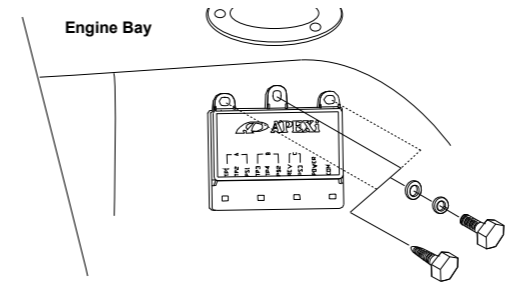

- CAUTION**
- Be sure to mount the meter away from electrical interference or noise (ex: Ignition Systems) to prevent malfunction.
 - Be sure to mount the sensor unit away from areas that may be exposed to water.
 - Be sure to keep the sensor unit away from constant HOT areas, please relocate when necessary.

★ Furthermore, for additional installation procedures, please reference the Instruction Manual of the DIN 3 Meter.